

SALT & VALVES

**C5-M TESTED
SEAWATER-RESISTANT
VALVES**



HAFNER



HAFNER offers a series of aluminum valves with EMATAL-coating. EMATAL parts have a sleek, wear-resistant, almost entirely non-porous surface that protects the aluminium.

As is also the case with classic anodising, EMATAL -coating involves an anodic oxidation process that produces a protective layer tightly bonded to the aluminium base material.

Enhancing the EMATAL -coated layers with titanium creates technical surfaces that have become indispensable in mechanical engineering and product design due to their excellent properties.

- C5-M tested according to ISO 12944
- Light-weight
- Cost-effective solution

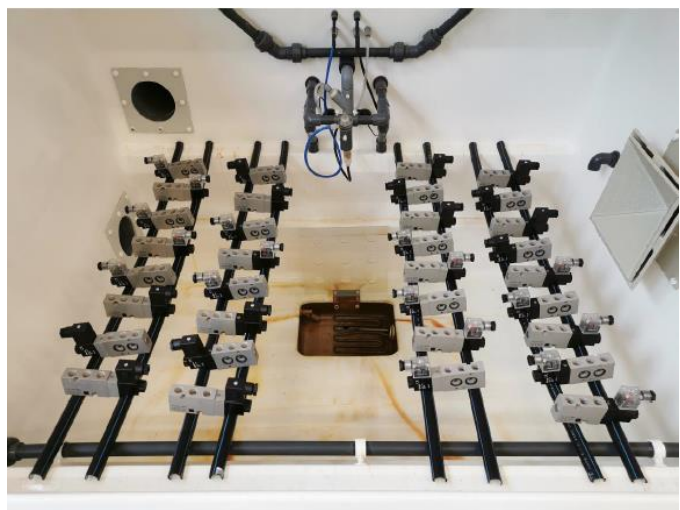

Salt spray chamber test

Valves suitable for corrosive atmosphere such as in offshore applications, ship building or the chemical industry.



If you have any further questions, please contact us:

E-Mail: info@hafner-pneumatik.de

Phone: 07154-178589-0



Apart from the EMATAL-coating of the body, we only use high-grade stainless steel components.

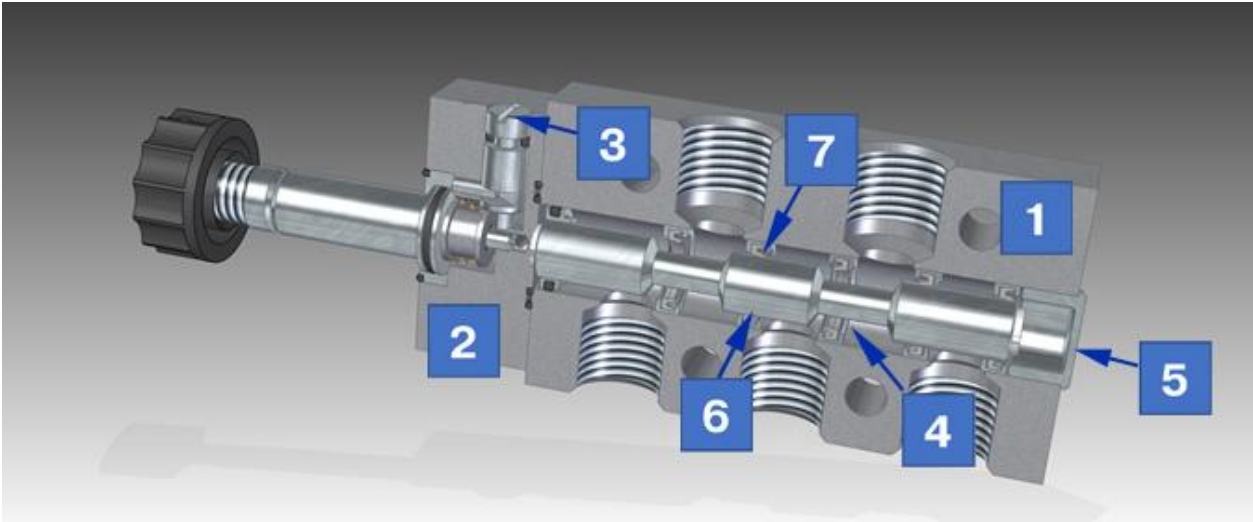

1	Valve body	Aluminum, EMATAL
2	Pilot-head	Aluminum, EMATAL
3	Manual override	1.4404 stainless steel
4	Rings	1.4404 stainless steel
5	Endcap	1.4404 stainless steel
6	Spool	1.4404 stainless steel
7	Seals	Series 701: PUR Series 121: FKM

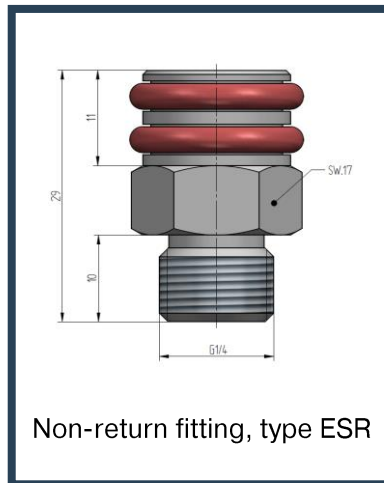

In order to extend the lifespan of the valve, we strongly recommend the use of our epoxy coil, to protect the exhaust ports by a non-return fitting as well as using a high-grade fixing screw for the connector.



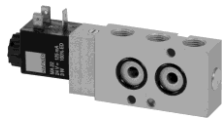

Page

NAMUR-Valves and flow regulator plates with EMATAL-coating

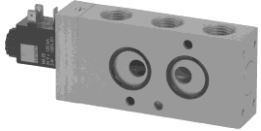
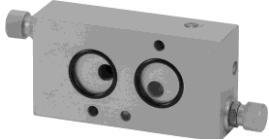
5	3/2-way & 5/2-way <ul style="list-style-type: none">▪ MNH 310 701 TT EMT▪ MNH 510 701 TT EMT▪ MNH 520 701 TT EMT	1/4"	
6	Flow regulator plates <ul style="list-style-type: none">▪ DRN 3 611 TT EMT▪ DRN 5 611 TT EMT	1/4"	
7	3/2-way & 5/2-way <ul style="list-style-type: none">▪ MNH 310 121 EMT▪ MNH 510 121 EMT▪ MNH 520 121 EMT	1/2"	
8	Flow regulator plates <ul style="list-style-type: none">▪ DRN 3 128 EMT▪ DRN 5 128 EMT	1/2"	

In-line solenoid valves with EMATAL-coating

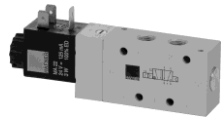
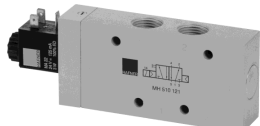
9	3/2-way & 5/2-way in-line <ul style="list-style-type: none">▪ MH 310 701 TT EMT▪ MH 510 701 TT EMT▪ MH 520 701 TT EMT	G 1/4"	
10	3/2-way & 5/2-way in-line <ul style="list-style-type: none">▪ MH 310 121 EMT▪ MH 510 121 EMT▪ MH 520 121 EMT	G 1/2"	



MNH 310 701 TT EMT/MNH 510 701 TT EMT/ MNH 520 701 TT EMT

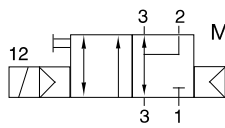

MNH 310 701 TT EMT

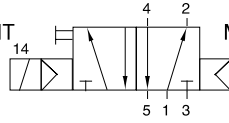

MNH 510 701 TT EMT

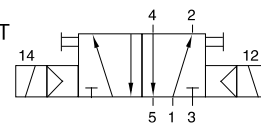

MNH 520 701 TT EMT

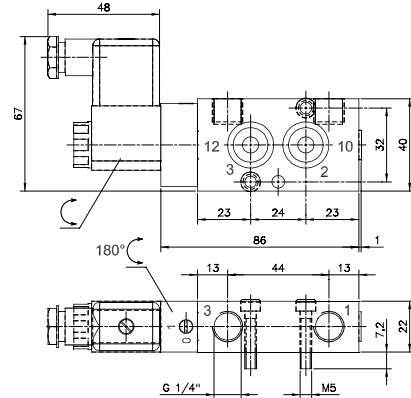
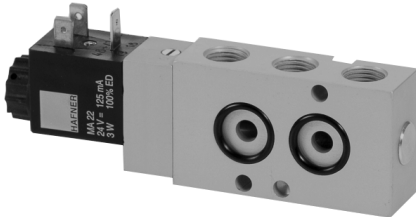

MNH 310 701 TT EMT

Solenoid valves with interface according to 1/4" NAMUR-standard.

MNH 310 701 TT EMT:

3/2-way solenoid valve, actuated by permanent signal, normally closed.

MNH 510 701 TT EMT:

5/2-way solenoid valve, actuated by permanent signal.

MNH 520 701 TT EMT:

5/2-way solenoid valve actuated by impulse. Position is kept until next electrical signal even when not attached to electrical source.

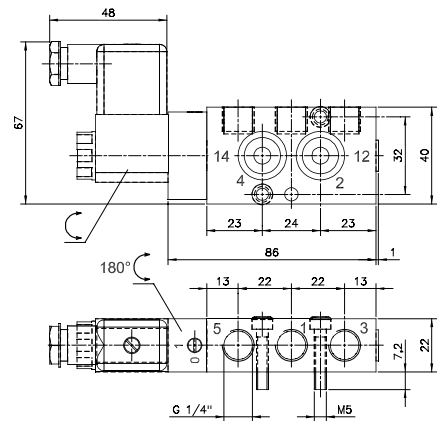

MNH 510 701 TT EMT

Generally with manual override to turn with solenoid operators 230V/50Hz, 110V/50Hz, 24V/50Hz, 48V=, 24V=, 12V=.

Please note:

When operated below 0°C the pressure condensation point has to be at least 15°C below the temperature of environment and media. Air has to be dried. Use unlubricated air only.

Delivery includes 1 pin, 2 screws 2 O-rings.

Temperature range:

-40°C ... +50°C (AC-coils) / +60°C (DC-coils)

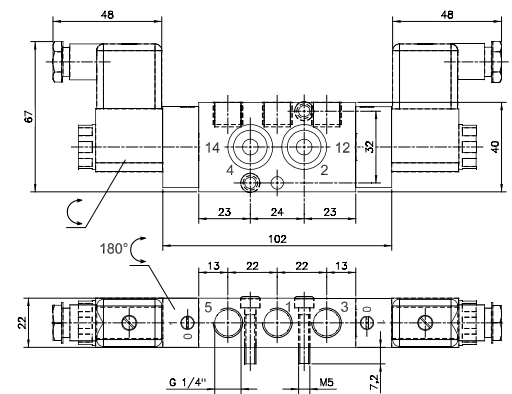

MNH 520 701 TT EMT

Type	Function	Port size	Air flow	Operating press.	Power consumption	Weight
MNH 310 701 TT EMT	3/2, n.c.	G 1/4"	1250 l/min	2 - 10 bar	3 W = / 5 VA ~	0,28 kg
MNH 510 701 TT EMT	5/2 spring-return	G 1/4"	1250 l/min	2 - 10 bar	3 W = / 5 VA ~	0,28 kg
MNH 520 701 TT EMT	5/2 bistable	G 1/4"	1250 l/min	2 - 10 bar	3 W = / 5 VA ~	0,38 kg





DRN 3 611 TT EMT/DRN 5 611 TT EMT

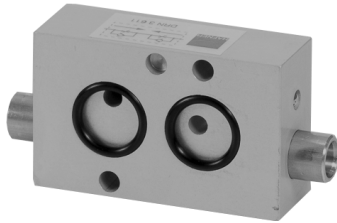
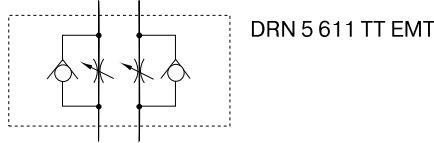
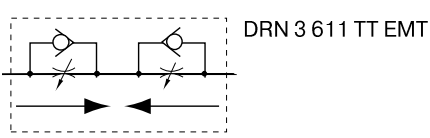

Block form flow regulator as intermediate plate, interface according to 1/4" NAMUR-standard.

DRN 3 611 TT EMT:

for 3/2-way valves with exhaust air recirculation only. To regulate the forward stroke of a single acting pneumatic actuator and to regulate the exhaust air going into the spring return unit independently. To be operated with a screw-driver.

DRN 5 611 TT EMT:

for 5/2 and 5/3-way valves only. To regulate the forward- and backward stroke of a double acting pneumatic actuator. To be operated with a screw-driver.

Please note:

When operated below 0°C the pressure condensation point has to be at least 15°C below the temperature of environment and media. Air has to be dried. Use unlubricated air only.

Delivery includes 1 pin, 2 screws (50 mm long)
2 O-rings.

Temperature range:
-40°C ... +50°C

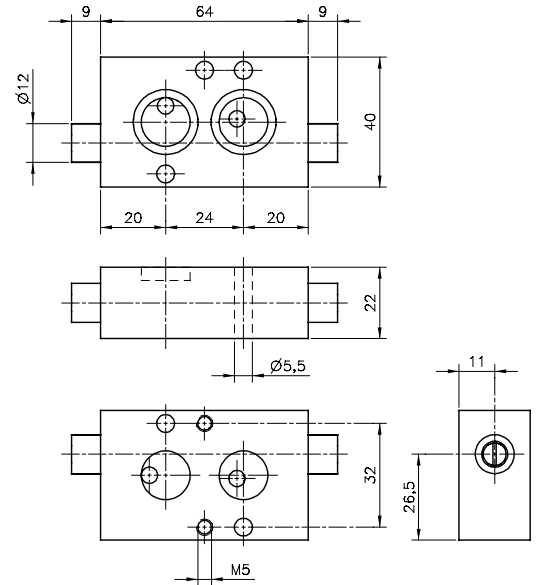

DRN 3 611 TT EMT

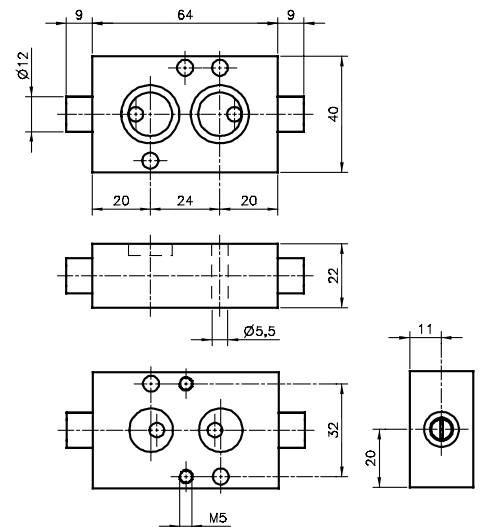

DRN 5 611 TT EMT

Type	Function	Port size	Max. air flow	Operating pressure	Weight
DRN 3 611 TT EMT	3-way	Ø 5 mm	650 l/min	0,5 - 10 bar	0,18 kg
DRN 5 611 TT EMT	5-way	Ø 5 mm	650 l/min	0,5 - 10 bar	0,18 kg





MNH 310 121 EMT/MNH 510 121 EMT/ MNH 520 121 EMT

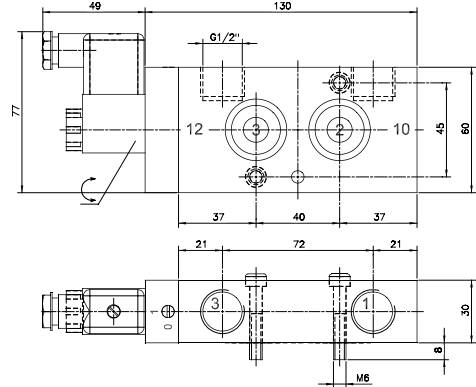
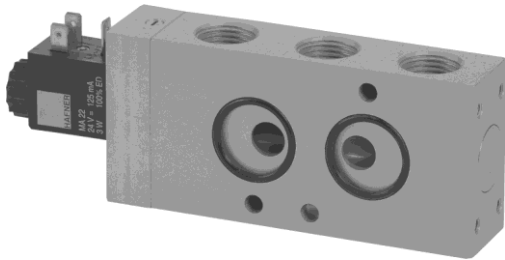
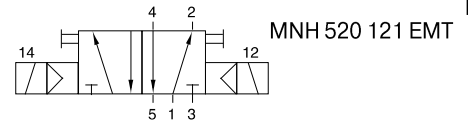
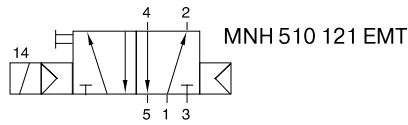
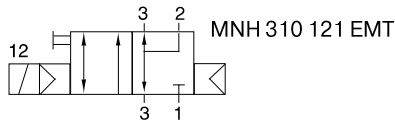

MNH 310 121 EMT

Solenoid valves with interface according to 1/2" NAMUR-standard.

MNH 310 121 EMT:

3/2-way solenoid valve, actuated by permanent signal, normally closed.

MNH 510 121 EMT:

5/2-way solenoid valve, actuated by permanent signal.

MNH 520 121 EMT:

5/2-way solenoid valve actuated by impulse. Position is kept until next electrical signal even when not attached to electrical source.

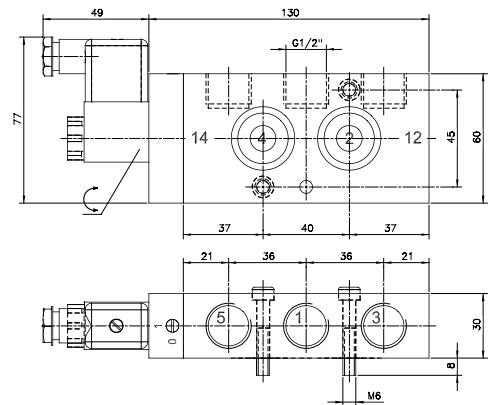

MNH 510 121 EMT

Generally with manual override to turn with solenoid operators 230V/50Hz, 110V/50Hz, 24V/50Hz, 48V=, 24V=, 12V=.

Delivery includes 1 pin, 2 screws 2 O-rings.

Temperature range:
-10°C ... +50°C (AC-coils) / +60°C (DC-coils)

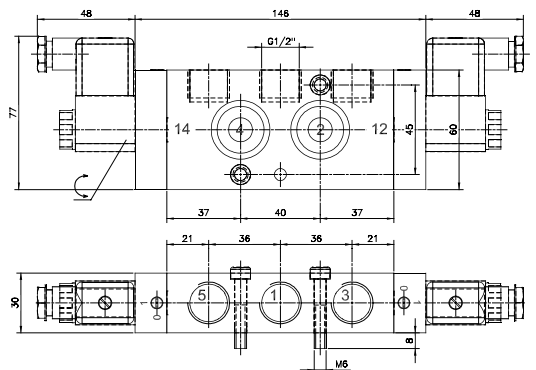

MNH 520 121 EMT

Type	Function	Port size	Air flow	Operating press.	Power consumption	Weight
MNH 310 121 EMT	3/2, n.c.	G 1/2"	3000 l/min	1 - 10 bar	3 W = / 5 VA ~	0,70 kg
MNH 510 121 EMT	5/2 spring-return	G 1/2"	3000 l/min	1 - 10 bar	3 W = / 5 VA ~	0,70 kg
MNH 520 121 EMT	5/2 bistable	G 1/2"	3000 l/min	1 - 10 bar	3 W = / 5 VA ~	0,87 kg





DRN 3 128 EMT/DRN 5 128 EMT

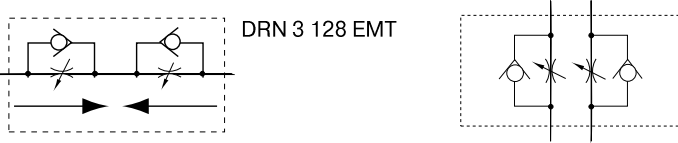

DRN 3 128 EMT

DRN 5 128 EMT



Block form flow regulator as intermediate plate, interface according to 1/2" NAMUR-standard.

DRN 3 128 EMT:

for 3/2-way valves with exhaust air recirculation only. To regulate the forward stroke of a single acting pneumatic actuator and to regulate the exhaust air going into the spring return unit independently. To be operated manually.

DRN 5 128 EMT:

for 5/2 and 5/3-way valves only. To regulate the forward- and backward stroke of a double acting pneumatic actuator. To be operated manually.

Delivery includes 1 pin, 2 screws, 2 O-rings.

Temperature range:
-10°C ... +50°C

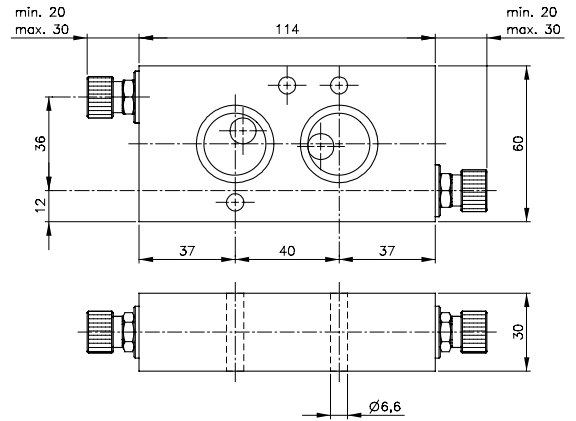

DRN 3 128 EMT

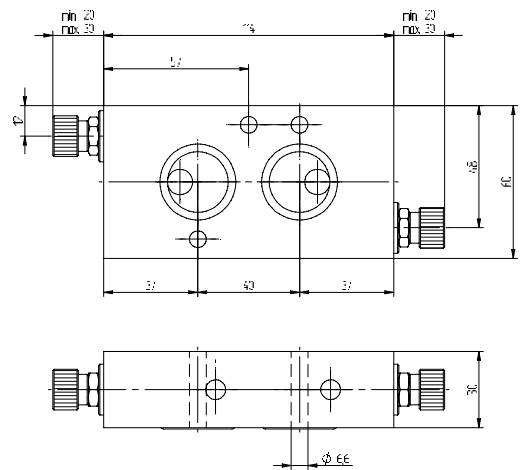

DRN 5 128 EMT

Type	Function	Port size	Max. air flow	Operating pressure	Weight
DRN 3 128 EMT	3-way	ø 8 mm	1.500 l/min	0,5 - 10 bar	0,60 kg
DRN 5 128 EMT	5-way	ø 8 mm	1.500 l/min	0,5 - 10 bar	0,60 kg





MH 310 701 TT EMT/MH 510 701 TT EMT/ MH 520 701 TT EMT

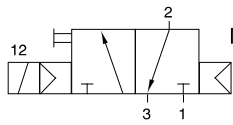

MH 310 701 TT EMT

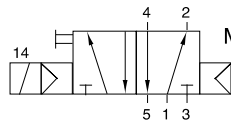

MH 510 701 TT EMT

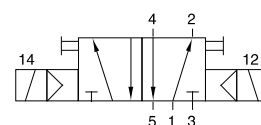

MH 520 701 TT EMT

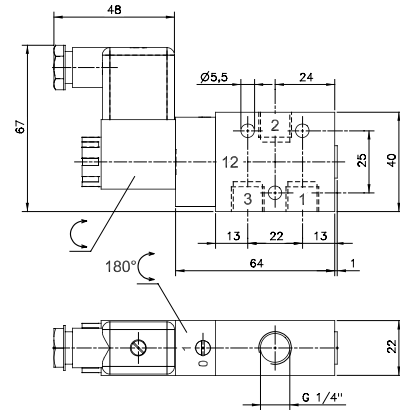
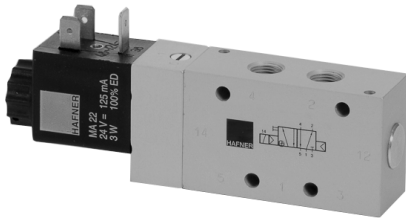

MH 310 701 TT EMT

MH 310 701 TT EMT:

3/2-way solenoid valve, actuated by permanent signal, normally closed.

MH 510 701 TT EMT:

5/2-way solenoid valve, actuated by permanent signal.

MH 520 701 TT EMT:

5/2-way solenoid valve actuated by impulse. Position is kept until next electrical signal even when not attached to electrical source.

Generally with manual override to turn with solenoid operators 230V/50Hz, 110V/50Hz, 24V/50Hz, 48V=, 24V=, 12V=.

Please note:

When operated below 0°C the pressure condensation point has to be at least 15°C below the temperature of environment and media. Air has to be dried. Use unlubricated air only.

Temperature range:

-40°C ... +50°C (AC-coils) / +60°C (DC-coils)

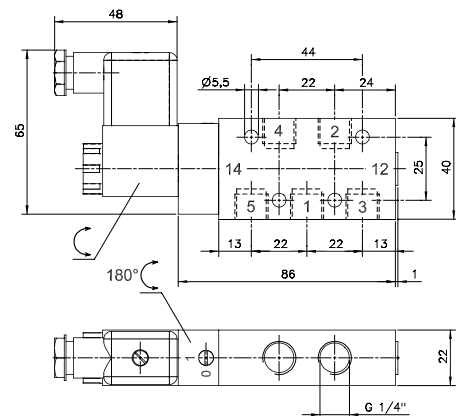

MH 510 701 TT EMT

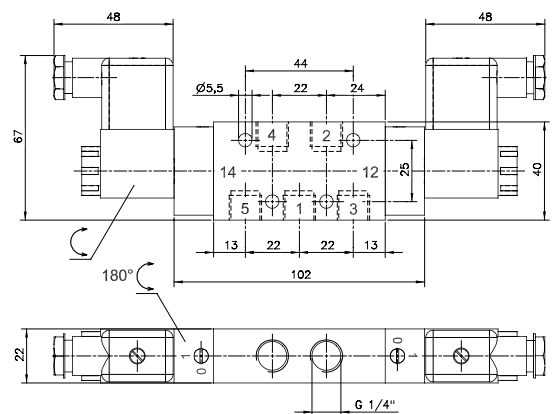

MH 520 701 TT EMT

Type	Function	Port size	Air flow	Operating press.	Power consumption	Weight
MH 310 701 TT EMT	3/2, n.c.	G 1/4"	1250 l/min	2 - 10 bar	3 W = / 5 VA ~	0,28 kg
MH 510 701 TT EMT	5/2 spring-return	G 1/4"	1250 l/min	2 - 10 bar	3 W = / 5 VA ~	0,28 kg
MH 520 701 TT EMT	5/2 bistable	G 1/4"	1250 l/min	2 - 10 bar	3 W = / 5 VA ~	0,38 kg





MH 310 121 EMT/MH 510 121 EMT/ MH 520 121 EMT

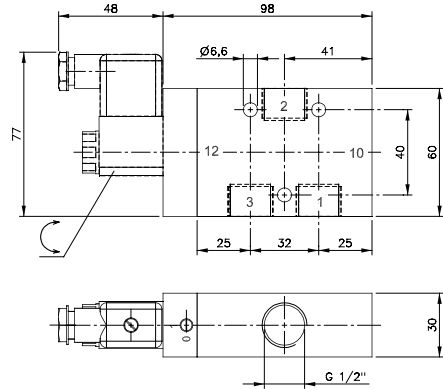
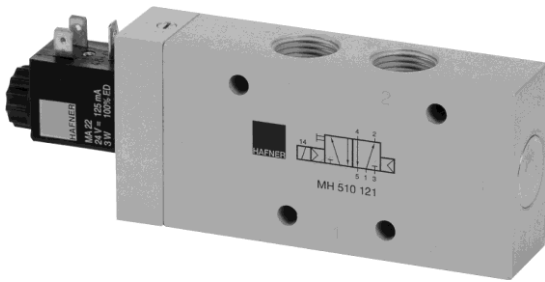
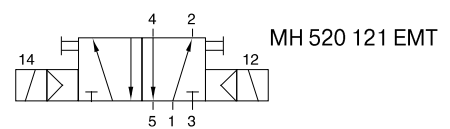
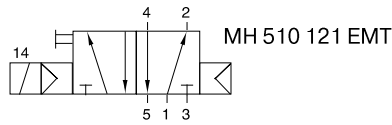
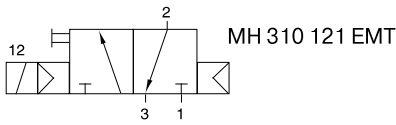

MH 310 121 EMT

MH 310 121 EMT:

3/2-way solenoid valve, actuated by permanent signal, normally closed.

MH 510 121 EMT:

5/2-way solenoid valve, actuated by permanent signal.

MH 520 121 EMT:

5/2-way solenoid valve actuated by impulse. Position is kept until next electrical signal even when not attached to electrical source.

Generally with manual override to turn with solenoid operators 230V/50Hz, 110V/50Hz, 24V/50Hz, 48V=, 24V=, 12V=.

Temperature range:
-10°C ... +50°C (AC-coils) / +60°C (DC-coils)

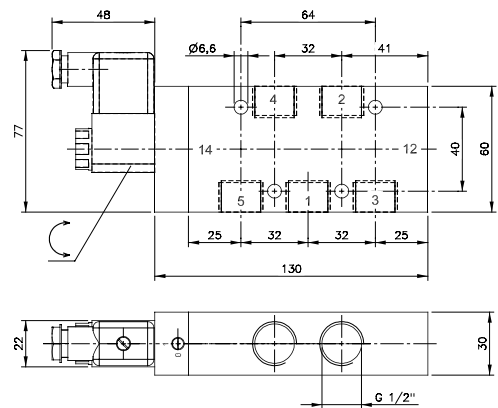

MH 510 121 EMT

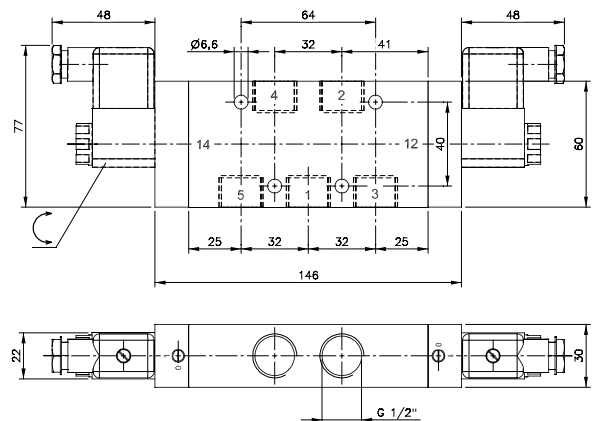

MH 520 121 EMT

Type	Function	Port size	Air flow	Operating press.	Power consumption	Weight
MH 310 121 EMT	3/2, n.c.	G 1/2"	3000 l/min	1 - 10 bar	3 W = / 5 VA ~	0,53 kg
MH 510 121 EMT	5/2 spring-return	G 1/2"	3000 l/min	1 - 10 bar	3 W = / 5 VA ~	0,67 kg
MH 520 121 EMT	5/2 bistable	G 1/2"	3000 l/min	1 - 10 bar	3 W = / 5 VA ~	0,84 kg





HAFNER

HAFNER Pneumatik Krämer GmbH & Co. KG
Stammheimer Straße 10
D-70806 Kornwestheim
Phone +49 - 71 54 - 17 85 890
Fax +49 - 71 54 - 17 85 89 28
info@hafner-pneumatik.de
www.hafner-pneumatik.de